

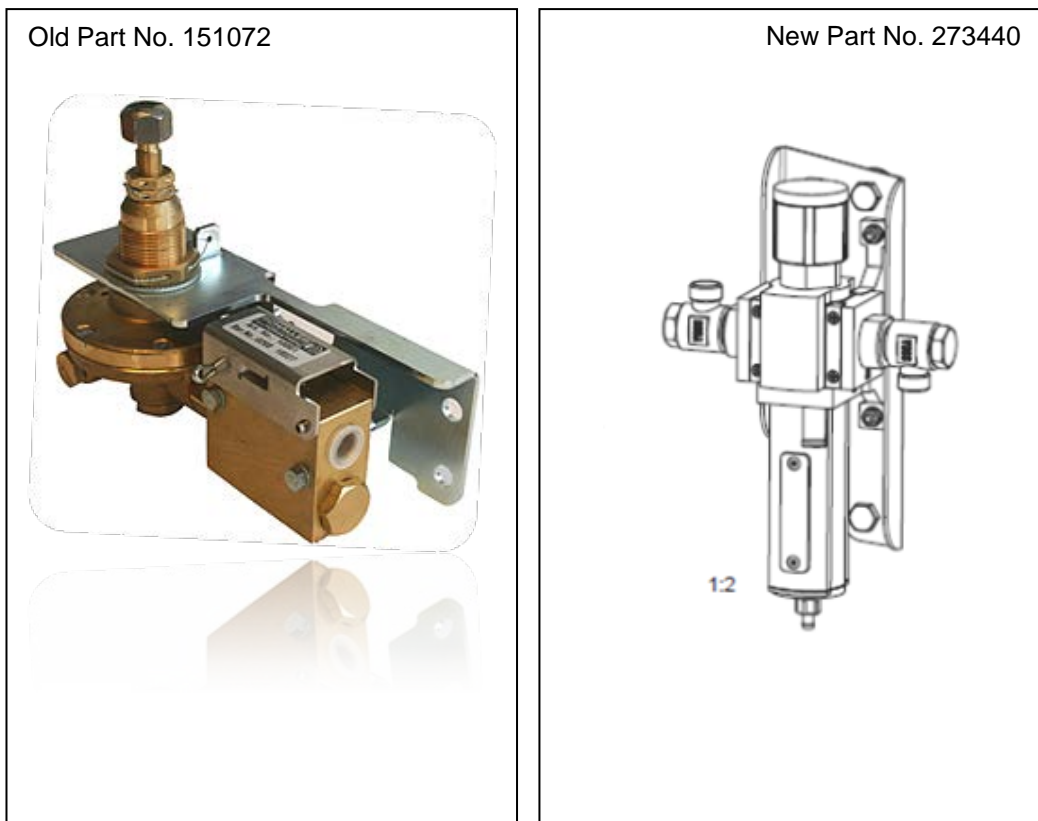

Schaller Automation – Newsletter Update “Pressure Regulator”

Schaller Automation consistently updates its product range and updates existing Oil Mist Detection systems and releases new systems for more convenient installation and with higher user-friendliness. The persistent effort Schaller Automation spends into the products Research & Development has made Schaller the industry leader. In order to keep our advanced position, we update our products and parts, we inform you with this Newsletter about the replacement of the previous Pressure Regulator design by the latest design. Please take note with immediate effect, that the updated design will be applicable and provided as Full Installation Kit (Schaller Part No. 273440) if a repair or replacement of the existing Pressure Regulating Unit (Schaller Part No. 151072 / 270443, old: 10001 / 11068) is required.



Please contact Schaller Automation Singapore in case of questions or clarification is required.

